

Ideal for
Public sector
Facility management
Leisure & outdoor
Last-mile



Garia Utility City

Use on busy and narrow streets any time of day or night (class L7e)



Ahhh, this is what a good workday feels like. The Garia Utility City thrives on navigating busy streets and narrow lanes. Small, agile and quick to accelerate, it flows seamlessly through the city.

Park without blocking traffic. Step in and out easily, safely and ergonomically, thanks to rear-hinged doors and a transparent cab. And a whisper-quiet drivetrain means you never disturb grouchy Mr. Jensen or his yappy dogs.

The road-legal bestseller
EU type-approved, the Garia Utility City can be registered for road use in all EU countries. Standard equipment includes 3-point seatbelts, adjustable side mirrors and E-marked headlights and tail lights. Configure the vehicle to meet your exact needs, including a wide range of options, accessories and batteries.

Download the product sheet at gariautility.com



TOP SPEED
45 KM/H



ROAD
LEGAL



RANGE UP TO
200 KM



BED LOAD
UP TO 800 KG



FITS NARROW
SPACES



CUSTOM
CONFIGURATIONS

Overall specifications

STANDARD CITY MODEL

Road approval	L7e	Hydraulic brakes	Standard
Speed up to	45 km/h / 28 mph	Automatic parking break	Standard
Range up to	200 km*	Bench seat	Standard
Bed load capacity	Up to 800 kg	Heated windscreen	Standard
48 volt	8 x 6 volt	Wipers & washer	Standard
Standard battery	T145 (lead acid)	Speedometer	Standard
Turning radius from	3.9 meters	Side mirrors	Standard
Full light pack	Standard	Seatbelts	Standard
On-board charger	Standard		

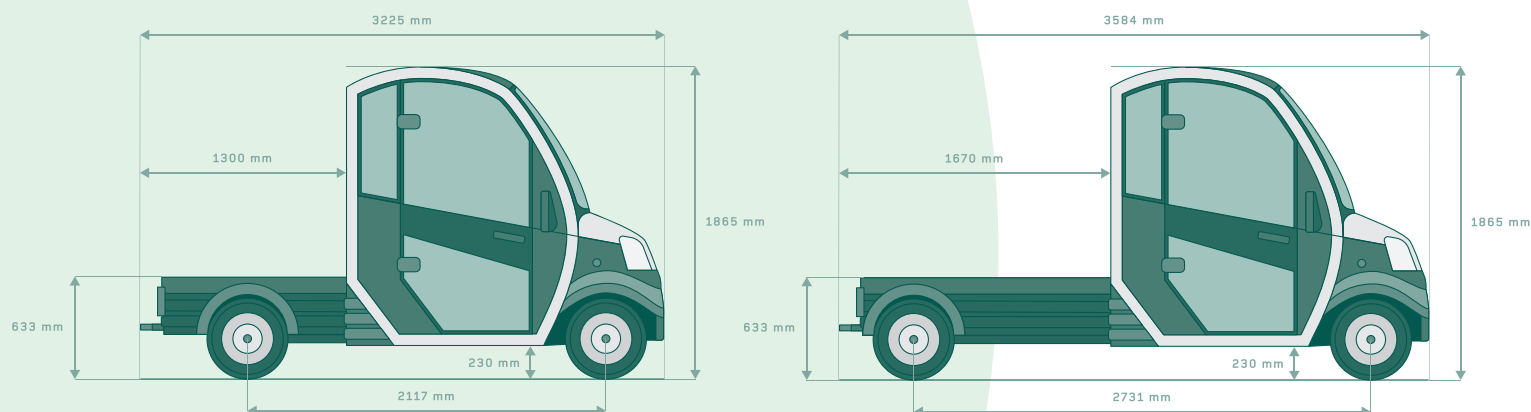

DIMENSIONS

	SHORT CHASSIS	EXTENDED CHASSIS
Width without side mirrors	1365 mm	1365 mm
Width with side mirrors	1731 mm	1731 mm
Length	3225 mm	3584 mm
Height	1865 mm	1865 mm
Bare chassis height	633 mm	633 mm
Ground clearance	230 mm	230 mm
Wheel base	2117 mm	2731 mm
Turning radius	3.9 m	4.6 m

LOAD

Front axle max load	730 kg	730 kg
Rear axle max load	945 kg	1120 kg
Bed load	400 kg	800 kg
Technically permissible maximum mass	1350 kg	1850 kg

PERFORMANCE

CITY MODEL

Standard-duty motor continuous power (S2=60min.)	3 kW (4Hp)
Peak power	11 kW (15Hp)
Heavy-duty motor continuous power (S2=60min.)	8 kW (11Hp)
Peak power heavy-duty motor	15 kW (20Hp)
Motor controller	Curtis 350 A
Battery (lithium is optional)	Trojan T145 8x6V
Battery capacity, 5h rate (lead acid)	215 Ah
Chassis: steel frame	Galvanized
Brakes, hydraulic: front / rear	Discs / Drums
Tires	165 / 70 R13 C 88
Top speed	45 km/h / 28 mph
Range WLTP 6 x 8V battery pack T875	-
Range WLTP 8 x 6V HD battery pack T145	60 km / 37 miles
Range lithium 120 Ah / 6.1 kWh	-
Range WLTP lithium 180 Ah / 9.2 kWh	75 km / 47 miles
Range WLTP lithium 200 Ah / 10.2 kWh	85 km / 52 miles
Range WLTP lithium 240 Ah / 12.2 kWh	100 km / 62 miles
Range lithium 420 Ah / 21.4 kWh*	200 km / 125 miles
Towing capacity (braked trailer)	-
Towing capacity (unbraked trailer)	-
Climb angle	25%

**Room to perform your best**

The market's most spacious, comfortable cab features unrivalled head and leg room, excellent visibility, and no wheel arches to block easy, speedy entry/exit. Everything is within reach of both the operator and passenger for maximum efficiency.

Garia Utility

Lunikvej 44B
2670 Greve
Denmark

Phone: +45 46 570 580

E-mail: sales@gariautility.com

Website: gariautility.com